

FF Series Fast Feet

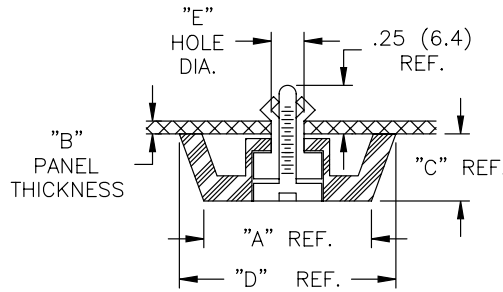

Features

- Push rivet to install, release by pushing pin from other side
- Press screw to install, release with screwdriver



WITH DRIVE SCREW

Fig. 1

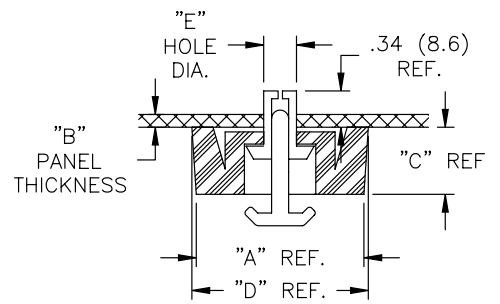

WITH PUSH RIVET

Fig. 2

Material: Foot - Thermoplastic Rubber, RMS-76 • Screw - Acetal, RMS-14• Rivet - Nylon 6, RMS-28
Color: Black

Part No.	"E" Hole Diameter	"B" Thickness Range	"A" Ref.	"C" Ref.	"D" Ref.	Fig. No.
FF-001B	.197 (5.0) - .201 (5.1)	.039 (1.0) - .091 (2.3)	.79 (20.0)	.55 (14.0)	.95 (24.0)	1
FF-004B		.039 (1.0) - .091 (2.3)	.71 (18.0)	.39 (10.0)	.79 (20.0)	
FF-015B		.031 (0.8) - .079 (2.0)	1.10 (28.0)	.59 (15.0)	1.18 (30.0)	
FF-003-P3X5.5B	.122 (3.1) - .126 (3.2)	.031 (0.8) - .071 (1.8)	.53 (13.5)	.22 (5.5)	.56 (14.2)	2
FF-005-P4X5B	.161 (4.1) - .165 (4.2)	.031 (0.8) - .071 (1.8)	.79 (20.0)	.17 (4.2)	.83 (21.0)	
FF-005-P4X6B		.071 (1.8) - .111 (2.8)				
FF-005-P4X7B		.114 (2.9) - .146 (3.7)				
FF-005-P4X8B		.150 (3.8) - .189 (4.8)				
FF-006-P4X6B		.024 (0.6) - .039 (1.0)				
FF-006-P4X7B		.039 (1.0) - .079 (2.0)				
FF-006-P4X8B	.079 (2.0) - .118 (3.1)	.55 (14.0)	.24 (6.0)	.59 (15.0)		
FF-006-P5X6.5B	.200 (5.1) - .205 (5.2)	.031 (0.8) - .047 (1.2)	.79 (20.0)	.31 (8.0)	.83 (21.0)	
FF-008-P4X6B	.031 (0.8) - .071 (1.8)					
FF-008-P4X7B	.075 (1.9) - .110 (2.8)					
FF-008-P4X8B	.114 (2.9) - .157 (4.0)					
FF-009-P4X6B	0 (0) - .031 (0.8)					
FF-009-P4X7B	.031 (0.8) - .079 (2.0)					
FF-009-P4X8B	.083 (2.1) - .118 (3.1)	.55 (14.0)	.35 (9.0)	.59 (15.0)		
FF-010-P4X6B	.024 (0.6) - .039 (1.0)					
FF-010-P4X7B	.039 (1.0) - .079 (2.0)					
FF-010-P4X8B	.079 (2.0) - .118 (3.1)					
FF-010-P5X6.5B	.032 (0.8) - .047 (1.2)					
FF-010-P5X7.5B	.047 (1.2) - .087 (2.2)					
FF-013-P3.5X4.5B	.142 (3.6) - .146 (3.7)	.020 (0.5) - .047 (1.2)	.39 (10.0)	.16 (4.0)	.43 (10.8)	
FF-013-P3.5X5.5B		.047 (1.2) - .079 (2.0)				
FF-013-P3.5X6.0B		.059 (1.5) - .087 (2.2)				
FF-013-P3.5X7.0B		.098 (2.5) - .126 (3.2)				
FF-013-P3.5X8.0B		.138 (3.5) - .165 (4.2)				

RIVETS, BUMPERS & FEET

SFF Series Soft Fast Feet

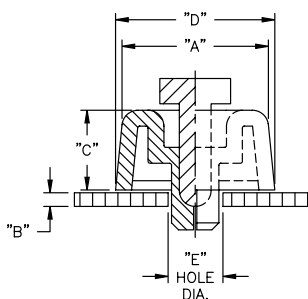

Features

- Slip and vibration resistant
- Two piece foot furnished pre-assembled

Material: Foot: Santoprene, RMS-42 • Pin: Polypropylene • Color: Black

Part No.	Standard Pack: 100 per bag				
	"E" ± .002 (0.05) Hole Dia.	"B" Thickness Range	"A" Ref. "	"C" Ref.	"D" Ref.
SFF-018	.305 (7.75)	.031 (0.8) - .059 (1.5)	.71 (18.0)	.39 (9.9)	.79 (20.1)
SFF-021		.197 (5.0) - .315 (8.0)	.79 (20.1)	.24 (6.1)	.83 (21.1)
SFF-023		.031 (0.8) - .059 (1.5)	.91 (23.1)	.20 (5.1)	.98 (24.9)
SFF-028		.031 (0.8) - .059 (1.5)	.71 (18.0)	.59 (15.0)	.79 (20.1)

BF-1001 Big Feet

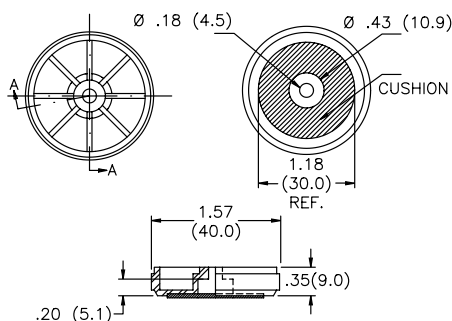

Foot Material: ABS • Cushion Material: Nylon Fiber
Color: Black

Standard Pack: 100 per bag

Recommended Mounting Screw: #8 (M-4) pan head; not furnished

Load Capacity: 22 lbs. (10 kg)

BF-1002 Big Feet

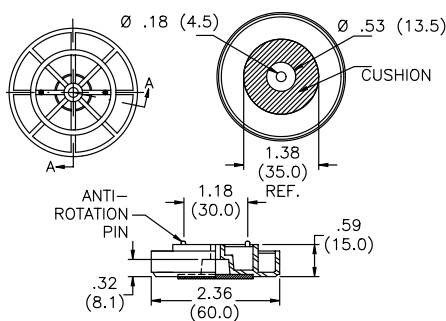

Foot Material: ABS • Cushion Material: Nylon Fiber
Color: Black

Standard Pack: 100 per bag

Recommended Mounting Screw: #8 (M-4) pan head; not furnished

Load Capacity: 22 lbs. (10 kg)

BF-1005 Big Feet

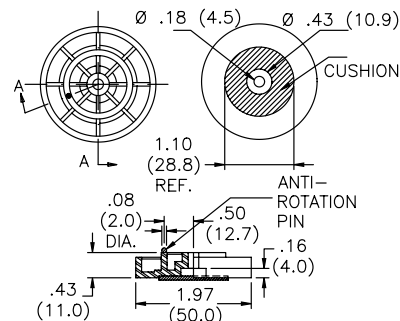

Foot Material: ABS • Cushion Material: Nylon Fiber
Color: Black

Standard Pack: 100 per bag

Recommended Mounting Screw: #8 (M-4) pan head; not furnished

Load Capacity: 22 lbs. (10 kg)

POF Series Push On Feet

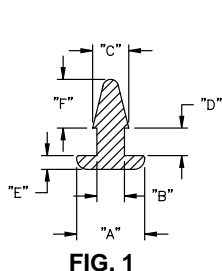

FIG. 1

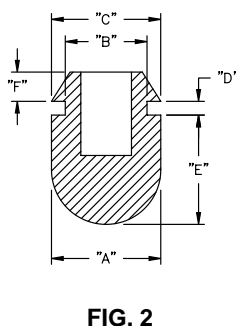

FIG. 2

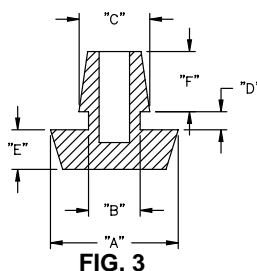

FIG. 3

Features

- Ideal for use on metal or plastic housings and cases
- Simply push into punched or drilled holes

Material: Flexible PVC, 55A durometer
Color: Black

Part No.	Standard Pack: 100 per bag						
	"A" Dia.	"B" Dia.	"C" Dia.	"D"	"E"	"F"	Fig #
POF-40022	.31 (7.9)	.126 (3.2)	.17 (4.3)	.13 (3.3)	.06 (1.5)	.16 (4.1)	1
POF-40048	.31 (7.9)	.188 (4.8)	.23 (5.8)	.06 (1.5)	.09 (2.3)	.14 (3.6)	1
POF-40059	.50 (12.7)	.374 (9.5)	.48 (12.2)	.06 (1.5)	.50 (12.7)	.14 (3.6)	2
POF-50185	.54 (13.7)	.247 (6.3)	.30 (7.6)	.08 (2.0)	.18 (4.6)	.35 (8.9)	3
POF-12664	.62 (15.7)	.277 (7.0)	.34 (8.6)	.05 (1.3)	.20 (5.1)	.16 (4.1)	3